

# Turbocast 800™ Towable Dual Action Grit/Salt Spreader

A grit/salt spreader with a 200 litre capacity that can be used as a broadcast or drop spreader. Ideal for use by local authorities to grit city/town centres, small to medium sized industrial sites and private roads.

## Broadcast Spreads

An 8 metre spread can be covered at towing speeds from 5 - 20mph, to suit towing vehicle and application.



## Drop Spreads

For accurate, controlled spreading, eliminating any waste grit/salt.



## DESIGN FEATURES

- Durapol® material hopper - will not rust, chip or corrode.
- Low maintenance stainless steel chassis, drive mechanism & broadcast spinner plate.
- Consistently distributed 8 metre spread width.
- Unique agitation mechanism spreads wet or dry grit/salt.
- Durapol side deflectors create drop-spreading action for accurate high dosage treatments.
- Spread adjustment mechanism for complete control of spread output from 5 - 40 g/ms.
- Adjustable speed control allows for uniform spread output range from 5 - 20mph.
- ON/OFF switch for drive engagement/disengagement to minimise wastage when travelling between sites.
- Adjustable height tow bar with pin hitch or ball hitch coupling.
- Encapsulated drive mechanism for low maintenance operation.

## DIMENSIONS

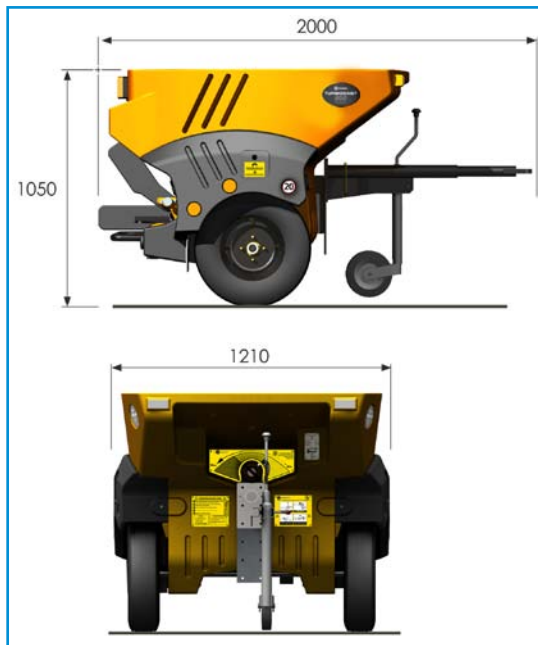

Capacity:	200 litres (approx. 10 x 25kg bags)
Maximum payload:	250kg*
Unladen weight:	170kg
Maximum laden weight:	420kg
Maximum spreading width:	8 metres
Maximum towing speed:	20mph

\* The weight of grit/salt is highly dependent on type and moisture content.

### Optional Extra

Amber flashing light



**Glasdon®**

**Glasdon U.K. Limited**

Preston New Road  
BLACKPOOL  
Lancashire  
FY4 4UL

Tel: (01253) 600410

Fax: (01253) 792558

e-mail: sales@glasdon-uk.co.uk

web: www.glasdon.com

# Durapol® material is a polymer formulated to withstand extremes of temperature and is impact-tested in our Quality Assurance Laboratory as part of our BS EN ISO 9001:2008 test procedure.  
Durapol® material will not chip or rust, is easy to clean and never needs painting.